

**Assembler Code Instructions – additional instruction normally outwith the scope of Advanced Higher**

iorlw	IOR literal and W	inclusive or (logic OR) literal and W value
iorwf	IOR W and file	inclusive or (logic OR) literal W and file value
xorlw	XOR literal and W	exclusive or (logic XOR) literal and W value
xorwf	XOR W and file	exclusive or (logic XOR) W and file value
andlw	AND literal with W	and (logic AND) literal and W value
andwf	AND w and file	and (logic AND) W and file value
comf	complement file	complement (logic NOT) the value in the file
rlf	rotate left file	rotate file bitwise to left via carry
rrf	rotate right file	rotate file bitwise to right via carry

Description of function	Assembler Mnemonic
Configure pins 7-4 outputting and pins 0-3 for inputting	bsf STATUS,RP0 movlw b'00001111' movwf TRISB bcf STATUS,RP0
set pin 0 high	bsf PORTB,0
set pin 0 low	bcf PORTB,0
set pins 7-4 high	movlw b'11110000' movwf PORTB
set a delay of 5 seconds	movlw d'50' call wait

# Technological Studies

## Advanced Higher

### Data Booklet

**For the use of candidates during coursework and in examinations**

Edition: March 2001  
Price: £0.50  
Publication code: G1313  
ISBN: 1 85969 3806

Published by the Scottish Qualifications Authority  
Hanover House, 24 Douglas Street, Glasgow G2 7NQ, and Ironmills Road, Dalkeith, Midlothian EH22 1LE

*The information in this publication may be reproduced to support SQA qualifications. If it is reproduced for any other purpose then SQA should be clearly acknowledged as the source in the reproduction.*





© Scottish Qualifications Authority 2001

### Assembler Code Instructions

bsf	bit set file	set a single bit to logic level '1'
bcf	bit clear file	clear a single bit to logic level '0'
btfsc	bit test file, skip if clear	skip next command if a single bit is clear '0'
btfss	bit test file, skip if set	skip next command if a single bit is set '1'
clrf	clear file	clear a file to value 0
clrw	clear W	clear W to 0
movlw	move literal to W	move a byte value into W
movwf	move W to file	move the value in W into a file
movfw	move file to W **	move the value in a file into W
addlw	add literal to W	add byte value to W value
addwf	add W and file	add W value to the file value
sublw	subtract literal from W	subtract literal from W
subwf	subtract W from file	subtract W from file value
incf	increment file	increment (add 1) to value of file
decf	decrement file	decrement (take 1) from value of file
incfsz	increment file, skip if zero	increment file, skip next command if equal 0
decfsz	decrement file, skip if zero	decrement file, skip next command if equal 0
goto	go to address	jump to new address
call	call sub procedure	call a sub-procedure
return	return from sub procedure	return from sub-procedure
nop	no operation	create a short time delay
sleep	sleep	Enter low power sleep mode

Copies are available from the Sales Section at SQA,  
telephone 0141-242 2168

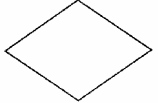
## Symbols for Flow Charts

Data symbol		Data, medium unspecified. Usually used for inputs and outputs
Line symbol		A line represents the flow of data or control. Solid or open arrowheads can be added to indicate the direction of flow
Process symbol		Predefined process consisting of one or more program steps specified elsewhere
Decision symbol		Decision or switching type of function with a single entry but two alternative exits, only one of which is activated after evaluation of the condition shown in the symbol
Sub procedure symbol		Entry to or exit from a sub-procedure
Special Symbol		Terminator – an exit to or an entry from the outside environment

## Contents

	Page
Basic Units	5
Decimal Prefixes	5
Formulae	6
Young's Modulus and Stress	8
Bending of Beams	9
Second Moment of Area	11
Standard Sections	12
Typical Operational Amplifier Circuits	15
Operational Characteristics for Thermistors, Thermocouple and LDR	18
Binary Weighting of Data Lines	21
Symbols for Flow Charts	22
Assembler Code Instruction Set	23

## Preface

This data booklet is intended for use by candidates in examinations in Technological Studies at Advanced Higher. It is recommended that candidates should become familiar with the contents of the data booklet through use in undertaking units of these courses.

It should be noted that the range of data contained in the booklet has been limited to that syllabus content which may be assessed through written examination papers. This range should be supplemented by other resource material as necessary during the course, e.g. by using data sheets. However, should any additional information (or data not included in this booklet) be required in an examination, such information will be included in the examination paper.

Teachers/lecturers should note that all of the material contained in this booklet is likely to be examined at some time. With regard to tables of information, not every entry in a table will necessarily be involved in examination questions.

From the variety of data offered in this booklet, candidates will be expected to demonstrate the ability to select an appropriate:

item of information;  
 formulae;  
 material property;  
 operational amplifier circuit;  
 Assembler Code instruction set.

## Binary Weighting of Data lines

7	6	5	4	3	2	1	0	Bits
$2^7$	$2^6$	$2^5$	$2^4$	$2^3$	$2^2$	$2^1$	$2^0$	
128	64	32	16	8	4	2	1	Weighting

### Decimal Binary Hexadecimal

0	0000	0
1	0001	1
2	0010	2
3	0011	3
4	0100	4
5	0101	5
6	0110	6
7	0111	7
8	1000	8
9	1001	9
10	1010	A
11	1011	B
12	1100	C
13	1101	D
14	1110	E
15	1111	F

### Writing Numbers

d'15'	decimal number 15
b'1111 0000'	binary number 11110000 (15 decimal)
h'0F'	hexadecimal number 0F (15 decimal)

## Light Dependent Resistor (LDR)

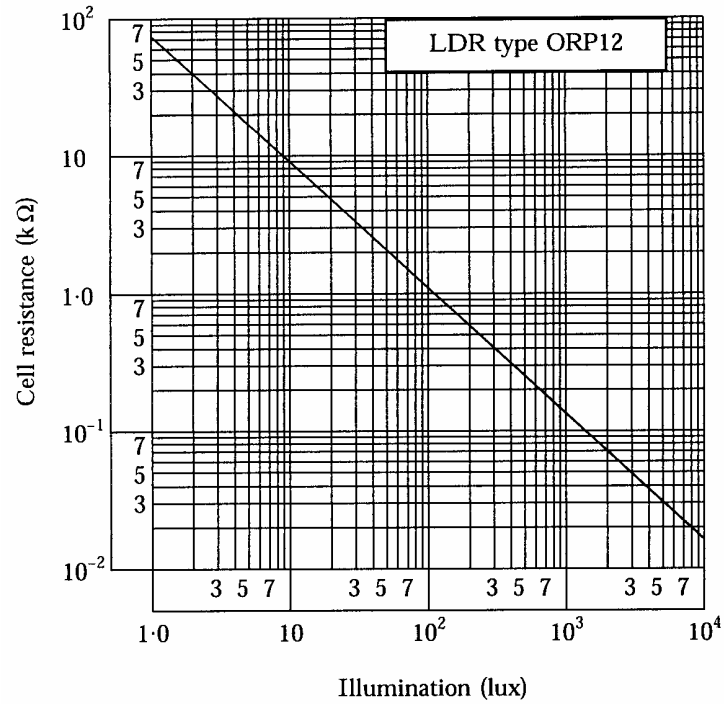

## Basic Units

Quantity	Symbol	Unit	Abbreviation
Length	<i>l, L</i>	Metre	M
Distance	<i>s, x</i>	Metre	m
Time	<i>t</i>	Second	s
Velocity	<i>v</i>	Metre/second	M/s
Mass	<i>m</i>	Kilogram	Kg
Force	<i>F</i>	Newton	N
Work	<i>W</i>	Joule	J
Energy	<i>E</i>	Joule	J
Power	<i>P</i>	Watt (J/s)	W
Stress	$\sigma$	Newton/metre <sup>2</sup>	N/m <sup>2</sup>
Strain	$\epsilon$		
Temperature	<i>T, t</i>	kelvin, celsius	K, °C
Current	<i>I</i>	ampere	A
Voltage	<i>V</i>	volt	V
Resistance	<i>R</i>	ohm	$\Omega$
Frequency	<i>f</i>	hertz	Hz

## Decimal Prefixes

prefix	symbol	multiplying factor
tera	T	10 <sup>12</sup>
giga	G	10 <sup>9</sup>
mega	M	10 <sup>6</sup>
kilo	k	10 <sup>3</sup>
milli	m	10 <sup>-3</sup>
micro	$\mu$	10 <sup>-6</sup>
nano	n	10 <sup>-9</sup>
pico	p	10 <sup>-12</sup>

## Electrical/Electronic

Ohm's law  $V = IR$

Resistors in series  $R_t = R_1 + R_2 + R_3 \dots$

Resistors in parallel  $\frac{1}{R_t} = \frac{1}{R_1} + \frac{1}{R_2} + \frac{1}{R_3} \dots$

for 2 resistors in parallel  $R_t = \frac{R_1 R_2}{(R_1 + R_2)}$

Bi-polar transistor gain  $h_{FE} = \frac{I_c}{I_b}$

## Structures

Stress  $\sigma = \frac{F}{A}$  A is the cross-sectional area  
the applied load

General Bending Equation  $\frac{M}{I} = \frac{\sigma}{y} = \frac{E}{R}$

Strain  $\epsilon = \frac{\Delta \ell}{\ell}$

Stress/strain relationship  $E = \frac{\sigma}{\epsilon}$  E is Young's Modulus

Moment of force  $M = Fx$  x is the perpendicular  
distance to pivot

Principle of moments  $\Sigma \text{ moments} = 0$

Factor of Safety (design factor)  $= \frac{\text{ultimate load}}{\text{safe working load}} = \frac{\text{ultimate stress}}{\text{safe working stress}}$

## Thermocouple

Typical temperature gradient for type K thermocouple

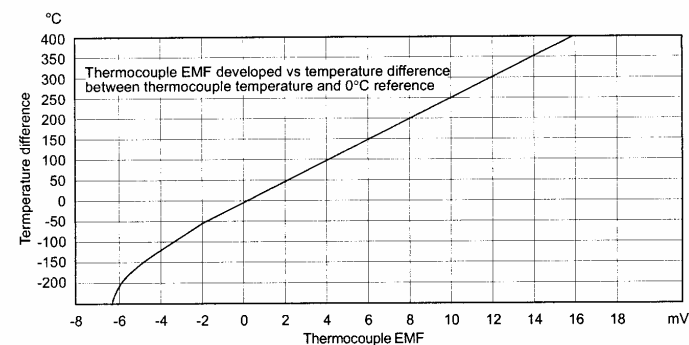

## Graphs for Thermistors, thermocouple and LDR

### Thermistors

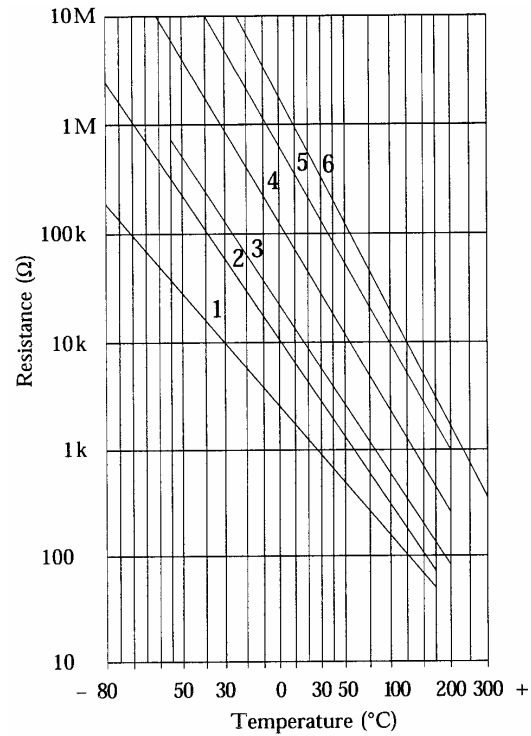

Thermistor Types	
1	151-136
2	151-142
3	256-045
4	151-158
5	256-051
6	151-164

### Additional Formulae

#### Applied Electronics

Mark:  $T_1 = 0.7(R_1 + R_2)C_1$

Space:  $T_2 = 0.7 R_2 C$

$$\text{Frequency} = F = \frac{1.44}{(R_1 + 2R_2)C}$$

#### Integrator Circuit

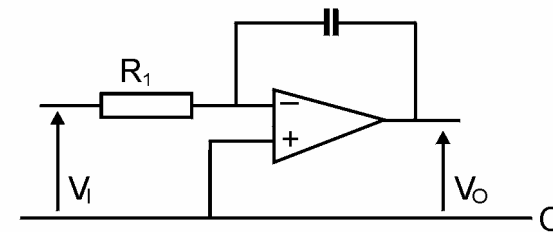

$$V_o = -\frac{1}{R_1 C} \int V_1 dt$$

## Young's Modulus and Stress

Material	Young's Modulus E kN/mm <sup>2</sup>	Yield Stress N/mm <sup>2</sup>	Ultimate Tensile Stress N/mm <sup>2</sup>	Ultimate Compressive Stress N/mm <sup>2</sup>
Mild steel	196	220	430	430
Stainless steel	190-200	286-500	760-1280	460-540
Low-alloy steels	200-207	500-1980	680-2400	680-2400
Cast iron	120	–	120-160	600-900
Aluminium alloy	70	250	300	300
Soft brass	100	50	80	280
Cast bronze	120	150	300	–
Titanium alloy	110	950	1000	1000
Nickel alloys	130-234	200-1600	400-2000	400-2000
Concrete	–	–	–	60
Concrete (steel reinforced)	45-50	–	–	100
Concrete (post stressed)	–	–	–	100
Plastic, ABS polycarbonate	2.6	55	60	85
Plastic, polypropylene	0.9	19-36	33-36	70
Wood, parallel to grain	9-16	–	55-100	6-16
Wood, perpendicular to grain	0.6-1.0	–	–	2-6
Soda glass	69	3600	–	–
Diamond	1000	50000	–	–
Gold	82	40	220	–
Ice	9.1	85	–	–

## Comparator

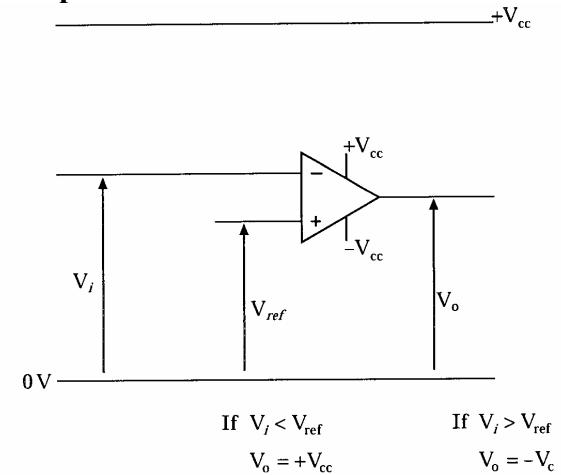

## Summing Amplifier

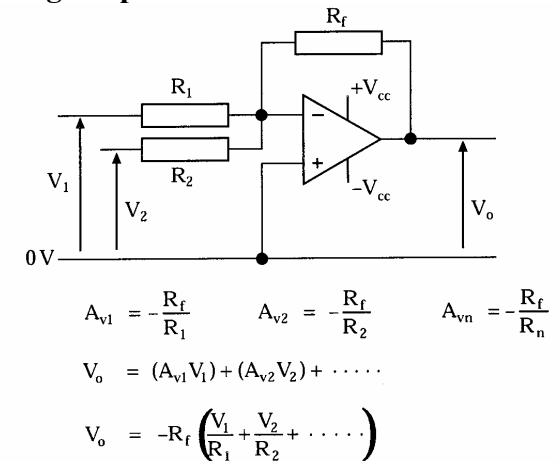

### Voltage Follower

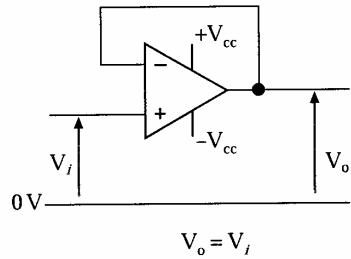

### Difference Amplifier

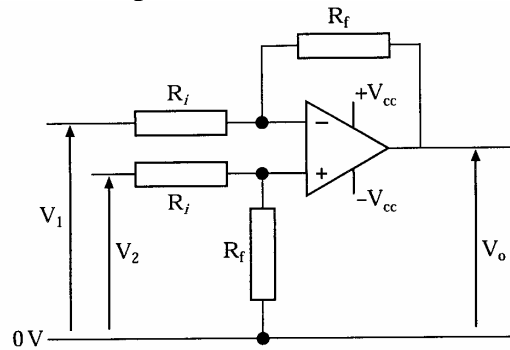

$$A_v = \frac{V_o}{(V_2 - V_1)}$$

$$A_v = \frac{R_f}{R_i}$$

$$V_o = \frac{R_f}{R_i} (V_2 - V_1)$$

### Bending of Beams

All beams of Length L, cross-section second moment of area I and Young's modulus E. Point C is located at mid-span.

$\omega$  = load per unit length (uniformly distributed load)

Configuration	Maximum Bending Moment	Maximum Deflection
	$FL$ at A	$\frac{FL^3}{3EI}$ at B
	$\frac{\omega L^2}{2}$ at A	$\frac{\omega L^4}{8EI}$ at B
	$\frac{FL}{4}$ at C	$\frac{FL^3}{48EI}$ at C

	$= \frac{\omega L^2}{8} \text{ at } C$	$= \frac{5\omega L^4}{384EI} \text{ at } C$
	$= \frac{FL}{8}$ $= -\frac{FL}{8} \text{ at } A, B$	$= \frac{FL^3}{192EI} \text{ at } C$
	$= \frac{\omega L^2}{24} \text{ at } C$	$= \frac{\omega L^4}{384EI} \text{ at } C$

### Typical Operational Amplifier Circuits

$V_o$  = output voltage       $V_i$  = input voltage       $V_{cc}$  = supply voltage

$R_f$  = feedback resistance     $R_i$  = input resistance     $A_v$  = gain =  $\frac{\text{output voltage}}{\text{input voltage}}$

#### Inverting

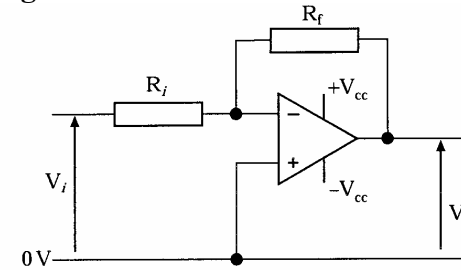

$$A_v = -\frac{V_o}{V_i}$$

$$A_v = -\frac{R_f}{R_i}$$

$$V_o = -\frac{R_f}{R_i} V_i$$

#### Non-inverting

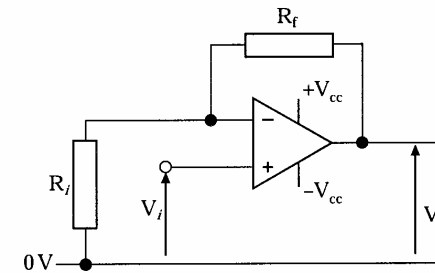

$$A_v = \frac{V_o}{V_i}$$

$$A_v = 1 + \frac{R_f}{R_i}$$

$$V_o = \left(1 + \frac{R_f}{R_i}\right) V_i$$

### Dimensions and Properties of Joists

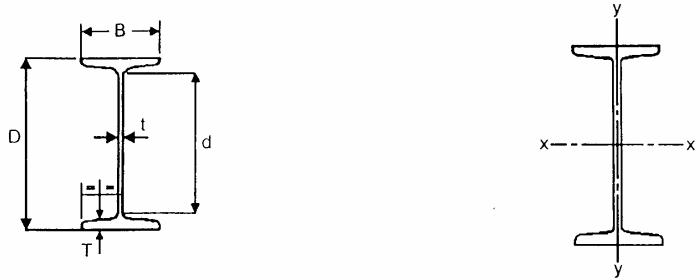

Nominal size	Mass per metre	Depth of section D	Width of section B	Thickness		Depth between fillets d	Area of section 1cm <sup>2</sup> =1x10 <sup>2</sup> mm <sup>2</sup>	Second moment of area 1cm <sup>4</sup> =1x10 <sup>8</sup> mm <sup>4</sup>	
				Web t	Flange T			Axis x - x	Axis y - y
mm	kg	mm	mm	mm	mm	mm	cm <sup>2</sup>	cm <sup>4</sup>	cm <sup>4</sup>
127 x 114	29.76	127.0	114.3	10.2	11.5	79.4	37.3	979.0	241.9
127 x 114	26.79	127.0	114.3	7.4	11.4	79.5	34.1	944.8	235.4
127 x 76	16.37	127.0	76.2	5.6	9.6	86.5	21.0	569.4	60.35
127 x 76	13.36	127.0	76.2	4.5	7.6	94.2	17.0	475.9	50.18
114 x 114	26.79	114.3	114.3	9.5	10.7	60.8	34.4	735.4	223.1
102 x 102	23.07	101.6	101.6	9.5	10.3	55.1	29.4	486.1	154.4
102 x 64	9.65	101.6	63.5	4.1	6.6	73.2	12.3	217.6	25.3
102 x 44	7.44	101.6	44.4	4.3	6.1	74.7	9.5	152.3	7.91
89 x 89	19.35	88.9	88.9	9.5	9.9	44.1	24.9	306.7	101.1
76 x 76	14.67	76.2	80.0	8.9	8.4	38.0	19.1	171.9	60.77
76 x 76	12.65	76.2	76.2	5.1	8.4	37.9	16.3	158.6	52.03

### Second Moment of Area (I) as used in bending equations

#### (i) Common Sections

Rectangle

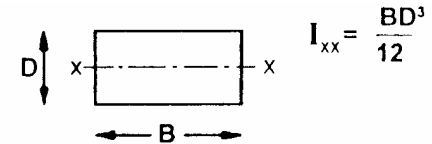

Solid Rod

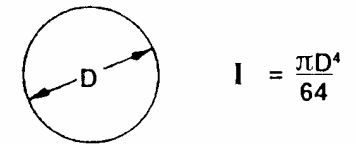

Tube

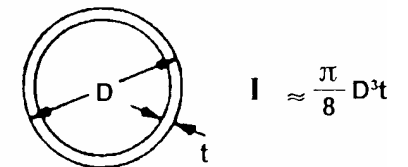

**(ii) Standard Sections**

This information has been extracted from ‘Steel section tables’ to illustrate the format used in such tables

**Dimensions and Properties of Square Hollow Sections**

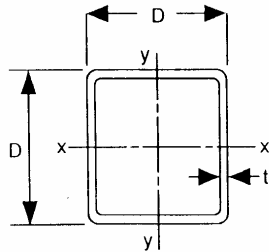

Designation		Mass per metre	Area of section A <small>1cm<sup>2</sup>=1x10<sup>2</sup>mm<sup>2</sup></small>	Second moment of area	
Size D x D	Thickness t			$I_{xx}$ <small>1cm<sup>4</sup>=1x10<sup>4</sup>mm<sup>4</sup></small>	
mm	mm	kg	cm <sup>2</sup>	cm <sup>4</sup>	
20 x 20	2.0	1.12	1.42	0.76	
	2.6	1.39	1.78	0.88	
30 x 30	2.6	2.21	2.82	3.49	
	3.2	2.65	3.38	4.00	
40 x 40	2.6	3.03	3.86	8.94	
	3.2	3.66	4.66	10.4	
50 x 50	4.0	4.46	5.68	12.1	
	3.2	4.66	5.94	21.6	
60 x 60	4.0	5.72	7.28	25.5	
	5.0	6.97	8.88	29.6	
60 x 60	3.2	5.67	7.22	38.7	
	4.0	6.97	8.88	46.1	
	5.0	8.54	10.9	54.4	

**Dimensions and Properties of Rectangular Hollow Sections**

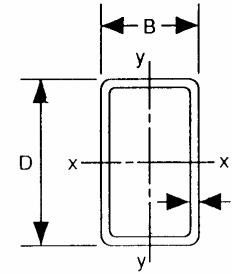

Designation		Mass per metre	Area of section <small>1cm<sup>2</sup>=1x10<sup>2</sup>mm<sup>2</sup></small>	Second moment of area <small>1cm<sup>4</sup>=1x10<sup>4</sup>mm<sup>4</sup></small>	
Size D x B	Thickness t			Axis x-x	Axis y-y
mm	mm	kg	cm <sup>2</sup>	cm <sup>4</sup>	cm <sup>4</sup>
50 x 30	2.6	3.03	3.86	12.4	5.45
	3.2	3.66	4.66	14.5	6.31
60 x 40	3.2	4.66	5.94	28.3	14.8
	4.0	5.72	7.28	33.6	17.3
80 x 40	3.2	5.67	7.22	58.1	19.1
	4.0	6.97	8.88	69.6	22.6
90 x 50	3.6	7.46	9.50	99.8	39.1
	5.0	10.1	12.9	130	50.0
100 x 50	3.2	7.18	9.14	117	39.1
	4.0	8.86	11.3	142	46.7
	5.0	10.9	13.9	170	55.1